

SS-15[®] Subsea Wellhead System

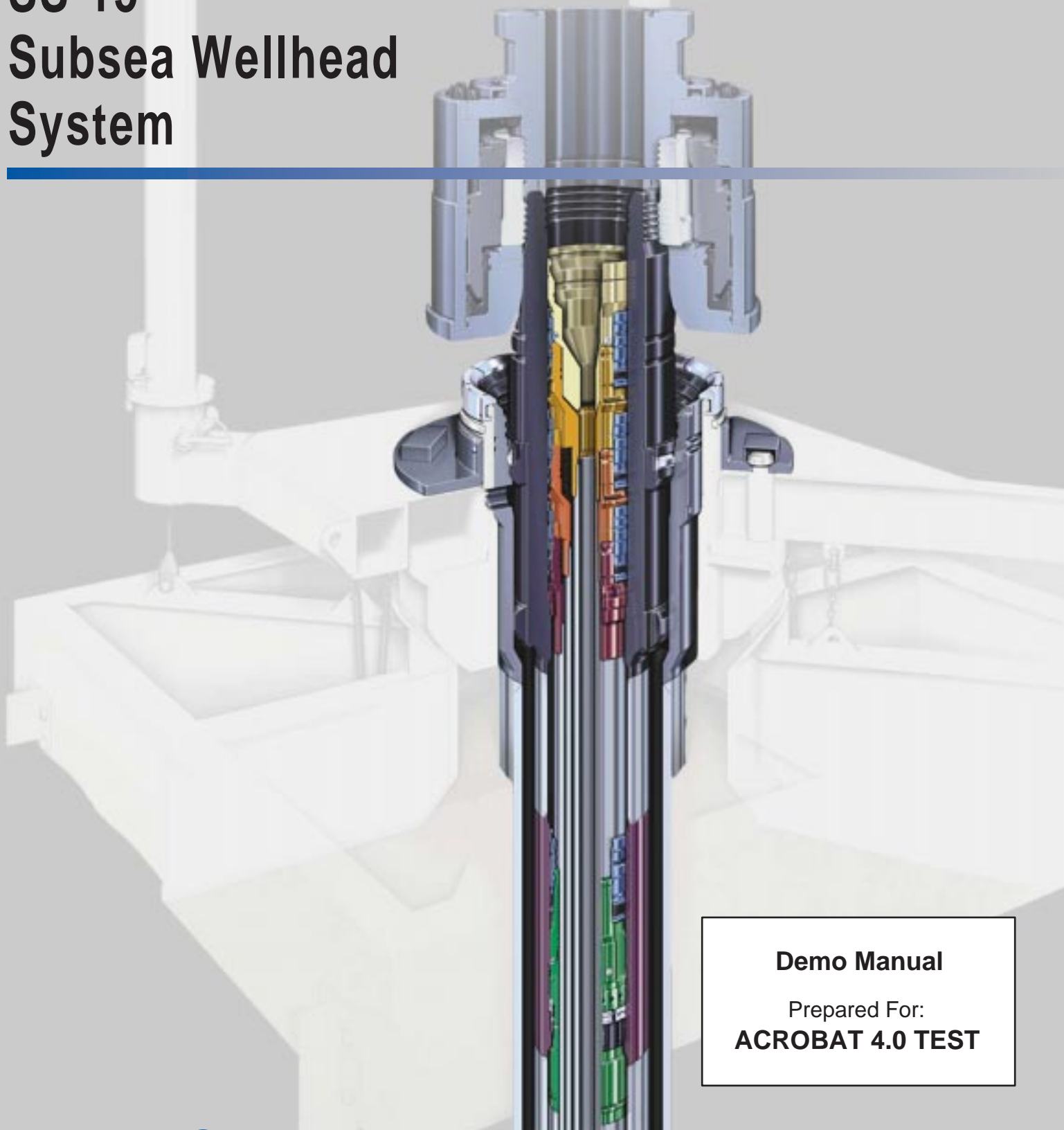

Demo Manual
Prepared For:
ACROBAT 4.0 TEST

DRIL-QUIP

13550 Hempstead Hwy. Houston, Texas 77040

NAVIGATIONAL HELP

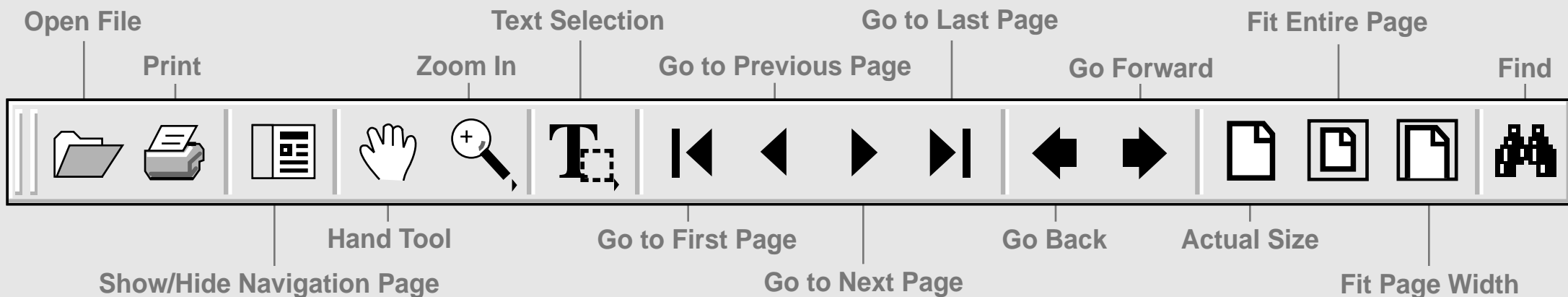

Move Mouse over tool to see more information

DRIL-QUIP'S NAVIGATION

MAIN TOC

Click to go to the General Table of Contents

TOC

Click to go to the current Procedure's Table of Contents

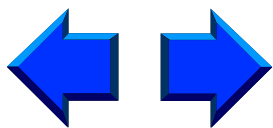

Click to go to the previous / next page

Figure

Click to zoom in on an Illustration
(Click the **Go Back** button to resume)

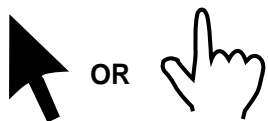

Indicates an item has an action or link



Show photograph
(Click the **Go Back** button to resume)

 For controlled zooming, draw a box around the item to be enlarged while in the Zoom tool.

 To zoom out hold down the Option key (Mac) or Control key (PC) and click.

TIPS FOR USING QUICKTIME™

The first time a link to a movie is activated, the following dialogue box appears. Click "All."



Close Movie

Play / Stop

Slide Bar

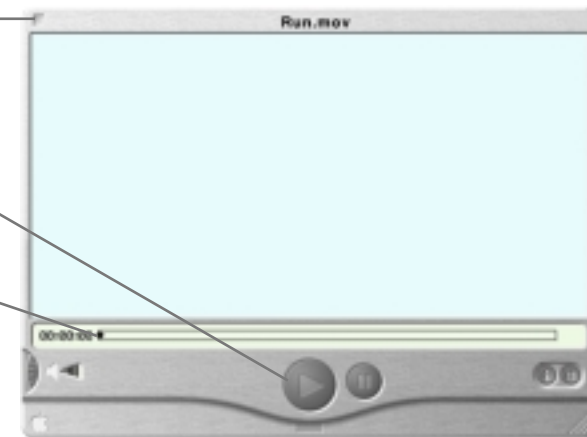

Movies appear in their own windows and need to be closed manually.

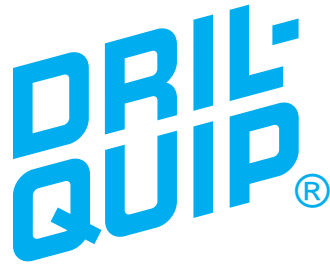

SERVICE MANUAL DEMO

PREPARED BY:
HEATHER DORITY

About this Demo

This is a very small representation of my work for Dril-Quip, an international deep sea drilling equipment manufacturer.

The actual manual design utilizes an average of 300 cross-linked documents burned to CD, while this demo has been reduced to one document for easier download from the web. Because of this, some navigation features will behave in slightly less intelligent ways and Quicktime movies will not play.

The average manual is approximately 200 times more detailed than this one. An example of the full version is available only for viewing in person, as the information is confidential and is the property of Dril-Quip.

Contact Heather DORITY for more information: heather@kukiri.com

Replication of this document or any of its parts is expressly forbidden



TABLE OF CONTENTS

HELP

INTRODUCTION

DRILLING PHASE

- TEST BOP STACK WITH BOP TEST TOOL
- RUN 18-3/4" NOMINAL BORE PROTECTOR
- RETRIEVE 18-3/4" NOMINAL BORE PROTECTOR
- RUN 13-3/8" CASING, CASING HANGER AND SEAL ASSEMBLY
- RUN 18-3/4" X 16" WEAR BUSHING
- RETRIEVE 18-3/4" X 16" WEAR BUSHING

ILLUSTRATED SEQUENCE

MOVIES

(Items in grey are not available for viewing)



TESTING THE
BOP STACK WITH THE BOP TEST TOOL
SUGGESTED PROCEDURE

Table of Contents

Tools Needed for This Operation _____ **2**

Pre-Operational Procedures _____ **2**

- BOP Test Tool _____ 3
- 18-3/4" Wellhead Housing Adapter _____ 4

Running Procedure _____ **5**

- MOVIE: Run BOP Test Tool on Top of Wear Bushing __ 5
- Testing The BOP Stack on the Primary Landing
Shoulder of the 18-3/4" Wellhead Housing _____ 5

Assembly Drawings and Parts Lists

420295-02 In-Line Jet Sub

Technical Specifications

18-3/4" BOP Test Tool
In-Line Jet Sub



TESTING THE
BOP STACK WITH THE BOP TEST TOOL
SUGGESTED PROCEDURE

The BOP stack test is accomplished with the BOP Test Tool when it is configured for existing operational conditions. The configuration of the BOP Test Tool is dependent upon the following operations:

- Testing on the primary landing shoulder of the Wellhead Housing
- Testing on the 16" Wear Bushing
- Testing on a Casing Hanger or Wear Bushing (other than the 16" Wear Bushing)
- Testing on a Wear Sleeve

Tools Needed for This Operation

- BOP Test Tool
- 18-3/4" Wellhead Housing Adapter (operation dependent)
- 18-3/4" x 16" Adapter (operation dependent)
- Wear Sleeve Adapter (operation dependent)
- In-Line Jetting Sub

Pre-Operational Procedures

All of the components of the SS-15 Subsea Wellhead System are carefully inspected at DRIL-QUIP's manufacturing facilities prior to shipping. Pre-operational procedures are suggested to ensure the equipment is not damaged due to shipping and handling, and to ensure all necessary components are available and in good working order when the equipment is used. If any of the following checks are suspect, contact the nearest DRIL-QUIP office.

BOP Test Tool

1. Refer to **Figure 1** for identification of the BOP Test Tool (Test Tool) components. Remove the Test Tool from its soluble oil bath storage can. Record the part number and serial number of the Test Tool for the permanent well file.
2. Ensure the Test Tool is free of debris and contamination. Wash the Test Tool with fresh water if cleaning is necessary.
3. Remove the protectors from the upper and lower tool connections. Check the threads for damage. Clean and lubricate the threads if necessary.
4. Inspect the seal element on the lower body of the Test Tool for damage which could keep the seal element from sealing against the Wellhead ID.
 - a. Confirm the seal element is smooth, pliable, and free of cuts and cracks.
 - b. Ensure the seal element OD is not larger than the OD of the actuator sleeve or seat. If the seal element OD is larger than the OD of the actuator sleeve or the OD of the seat, reset the actuator sleeve.
 - c. Reset the actuator sleeve if necessary. Make up three, 3/4" National Coarse screws in the releasing screw holes on the actuator sleeve until the sleeve moves back away from the seal element.

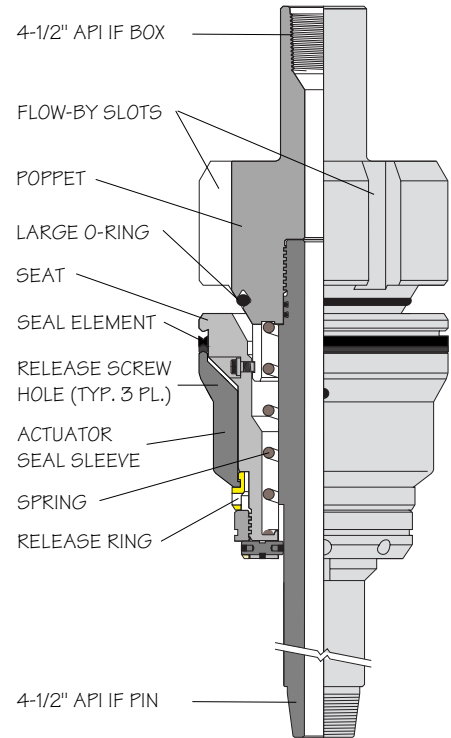

Figure 1. BOP Test Tool

18-3/4" Wellhead Housing Adapter

The Wellhead Housing Adapter is installed on the Test Tool to land the tool on the primary landing shoulder in the 18-3/4" Wellhead Housing.

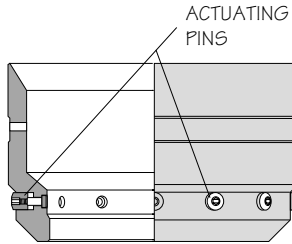

Figure 2. Wellhead Housing Adapter

1. Refer to **Figure 2** for identification of the Wellhead Housing Adapter components. Record the part number and serial number of the Wellhead Housing Adapter for the permanent well file.
2. Clean the Wellhead Housing Adapter and inspect it for damage.
3. Press the 12 actuators with a finger to verify they move freely. From inside the adapter, press each pin back out to their proper position. If the Wellhead Housing Adapter is already installed on the Test Tool, tap each actuator lightly with a hammer to verify they move freely.
4. Install the Wellhead Housing Adapter on the Test Tool if it was not previously installed. Refer to **Figure 3**.
 - a. Lay the Test Tool on its side.
 - b. Slip the Wellhead Housing Adapter onto the bottom of the Test Tool.
 - c. Insert the split retainer ring and seat it in the groove immediately below the bottom of the Wellhead Housing Adapter.

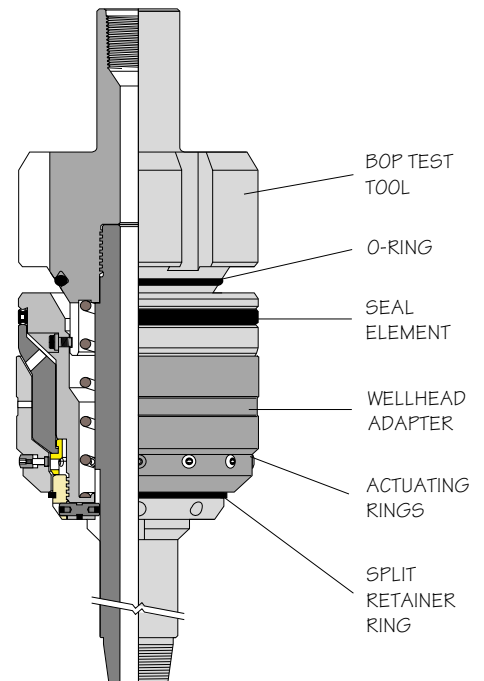

Figure 3. BOP Test Tool with Wellhead Adapter installed



Running Procedure

Note: The Test Tool cannot be used to test the BOP stack when the Nominal Bore Protector is installed in the Wellhead. The Nominal Bore Protector cannot support the loads generated by the pressure required to test the BOP stack.

Testing the BOP Stack on the Primary Landing Shoulder of the 18-3/4" Wellhead Housing

The following procedure and equipment configuration tests the BOP stack and Wellhead ring gasket when Casing Hangers or Wear Bushings are not installed in the Wellhead.

1. If the ball or flex joint has a Wear Bushing with a restrictive ID installed, retrieve this flex joint Wear Bushing before running the Test Tool.
2. Ensure the Nominal Bore Protector is removed from the Wellhead Housing before using the Test Tool.
3. Prepare the Test Tool.
 - a. Make up one stand of heavy wall drill pipe or drill collars to the drill pipe connection on the bottom of the tool.
 - b. Make up a smooth joint of 5" drill pipe to the top of the Test Tool.

Note: The Test Tool must have a minimum weight of 15,000 lb to activate its seal element. DRIL-QUIP recommends a stand of heavy wall drill pipe or drill collars be made up to the bottom of the tool, to assist in pulling the Test Tool into place. If the length of the running string does not supply the weight required to activate the seal element, additional stands below the Test Tool may be necessary.

TYPICAL PROJECTION

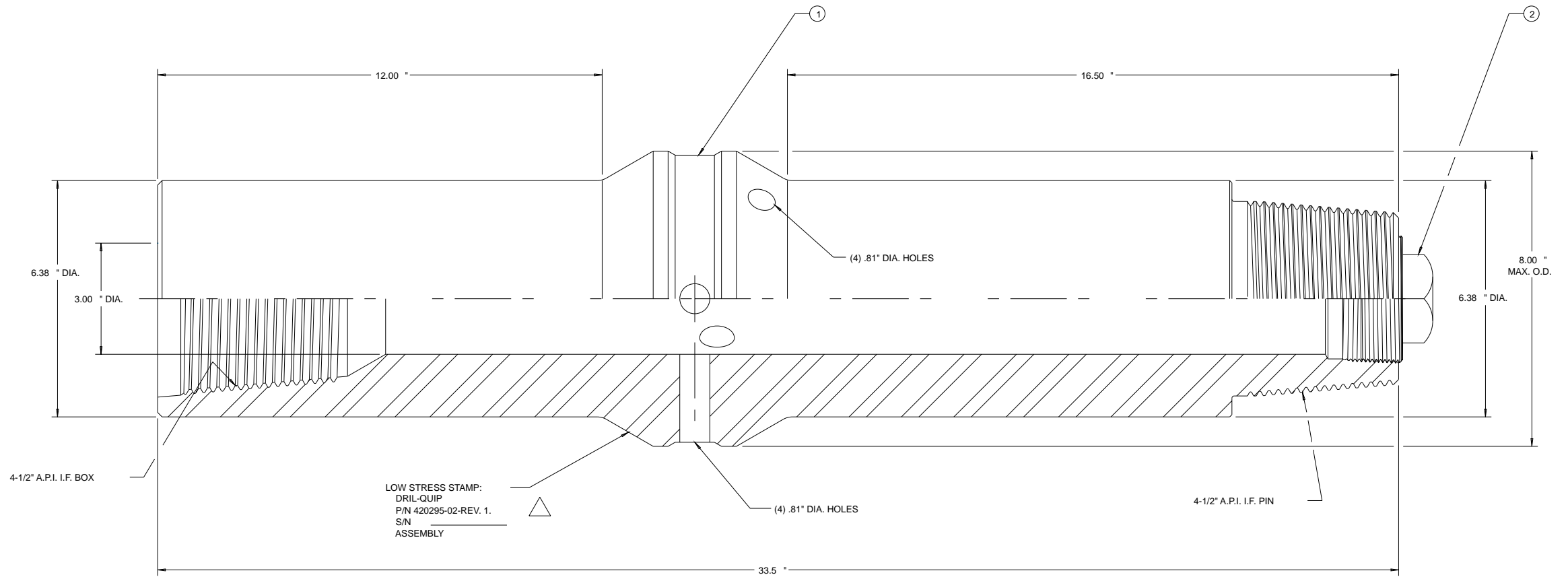

NOTES: 1. STAMP CURRENT REVISION LETTER FROM PARTS LIST.

REVISIONS					DWN. BY: JRC	
REV.	DATE	CHKD.	APP.	REL.	CHKD. BY:	EAB
A	25-OCT-90	EAB	GLH	JFE	APP. BY:	AS
B	12-NOV-90	WPE	AS	JFE	REL. BY:	JFE
C	13-NOV-90	EAB	AS	JFE	REL. DATE:	13-NOV-90
D	19-MAY-93	RTP	GLH	JFE	REF. LAYOUT:	
E						

ALL DIMENSIONS IN INCHES

SUBSEA WELLHEAD SYSTEMS TYPE SS-15/SS-10
18-3/4" JET SUB (SPECIAL).
W/8.00" MAX. OD, W/4-1/2" API IF BOX UP x PIN DOWN ASSEMBLY

DRIL-QUIP
DRIL-QUIP, INC.
HOUSTON, TEXAS

DWG SIZE	PART NUMBER	LAST REV
D	420295	E

CAD

ITEM NO	QTY	PART NUMBER	DESCRIPTION
1	1	423059	BODY,JET SUB;18.75"(SP)IF :FM
2	1	902148-12	PLUG,SOLID SQ HEAD 3" NPT

REVISIONS			SWS, SUB,JET;18.75"(SP)IF, SUBSEA WELLHEAD SYSTEMS TYPE SS-15/SS-1018-3/4" JET SUB (SPECIAL)W/8.00" MAX OD, W/4-1/2" API IF BOX UP X PIN DOWN, SPECIAL, ASSEMBLY ASSEMBLY			
REV	DATE	APPROVER	Drawn By:	DWG SIZE	PART NUMBER	REV
A	25-OCT-90	GLH	TPM		420295-02	C
B	13-NOV-90	AS	CDD			
C	07-MAR-95	GWC	GLH			
			JFE			
* SPARE PARTS			Rel. Date: 22-OCT-90		Sheet 1 of 1	
DRIL-QUIP DRIL-QUIP, INC. HOUSTON, TEXAS						

GO BACK

INLINE JET SUB

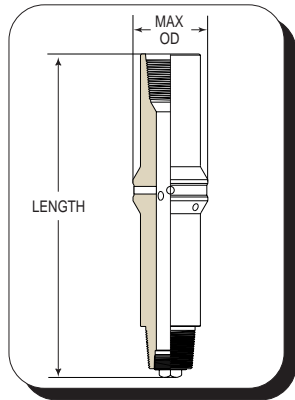

- Used in combination with the Multi-Purpose Tool Adapter Sub, the Jet Sub provides means of washing and/or flushing the ID of the wellhead and any components installed in it.
- Can be attached directly to the Multi-Purpose Tool by the Adapter Sub that allows for washing of components located further down in the wellhead.

NOM. SIZE (in)	MAX. OD (in)	MIN. ID (in)	LENGTH (in)	WEIGHT (lb)	JET FLOW AREA (in ²)	MAX. LOAD RATING (Million lb)
18-3/4	8	3	33.5	220	4.12	* 1.0

* Limited by 4-1/2" API IF Pin

BOP ISOLATION TEST TOOL

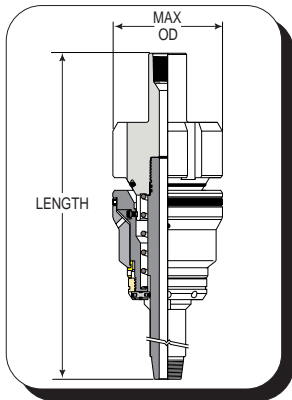

- The BOP Isolation Test Tool allows testing of the BOP Stack and the Wellhead after removal of the Nominal Bore Protector . A slip on adapter allows landing of the tool on the primary shoulder of the Wellhead.
- The BOP Isolation Test Tool allows testing of the BOP stack with any Wear Bushing installed. This method tests the BOP while isolating the Casing Hanger Seal Assembly from test pressure.
- Can be landed on top of a Casing Hanger with Wear Bushing removed. Seal Assembly is isolated from test pressure.
- Seal activation mechanism does not allow premature activation of the seal element.
- Ample flowby area facilitates running and prevents swabbing when the tool is retrieved.
- 4-1/2" API IF Box up and 4-1/2" API IF Pin down.

NOM. SIZE (in)	MAX. OD (in)	MIN. ID (in)	LENGTH (in)	WEIGHT (lb)	MAX. INT. OR EXT. PRESS. (psi)	MAX. HANGING CAPACITY (Million lb)
18-3/4	18.605	3.00	61.16	1,900	15,000	1.0
13-5/8	13.385	3.00	54.17	1,450	15,000	1.0

GO BACK

4-1/2" API IF BOX

FLOW-BY SLOTS

POPPET

LARGE O-RING

SEAT

SEAL ELEMENT

ACTUATOR
SEAL SLEEVE

RELEASE SCREW
HOLES (TYP. 3 PL.)

RELEASE RING

4-1/2" API IF PIN

BOP Test Tool

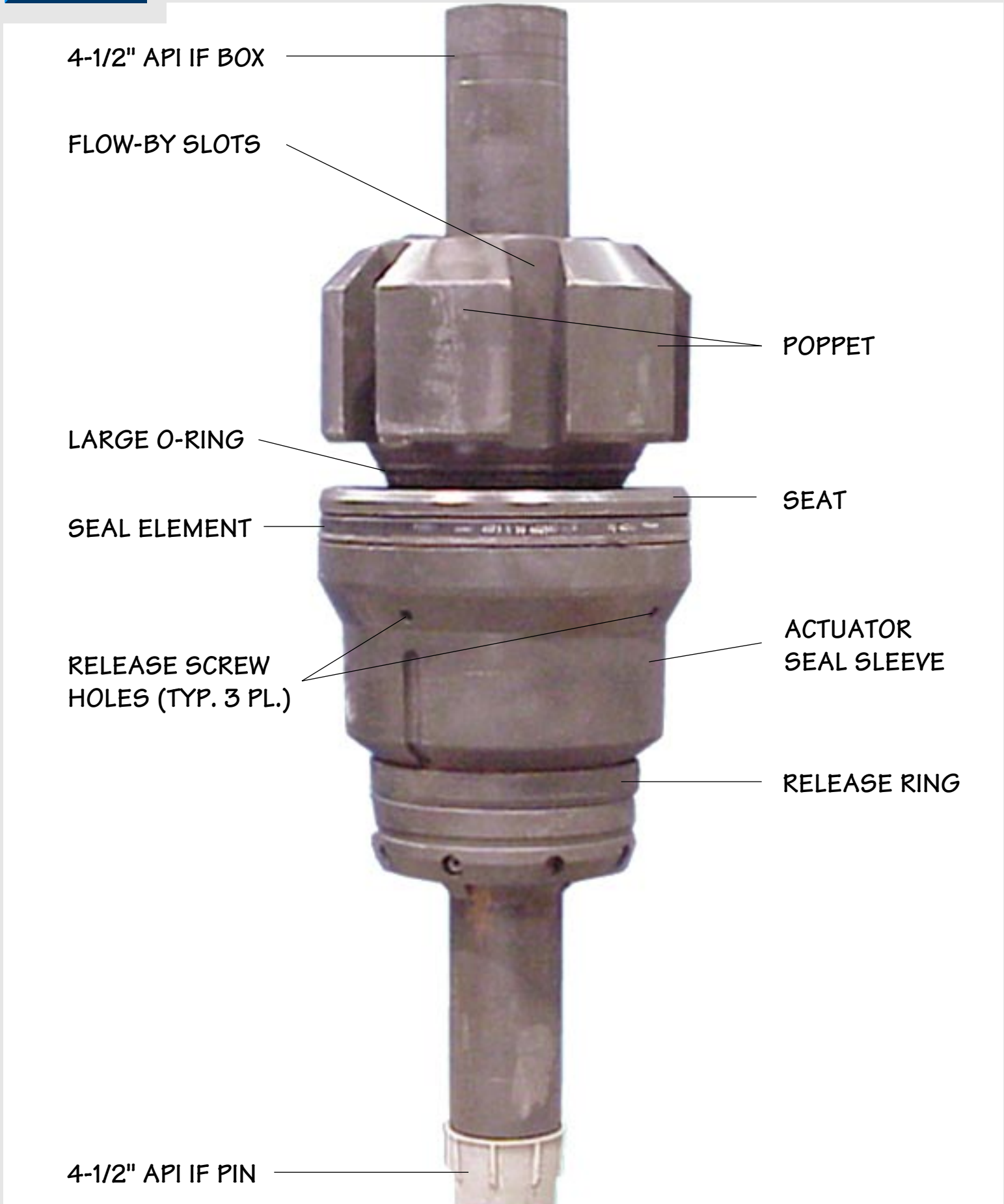

GO BACK

FIGURE 1.

BOP Test Tool

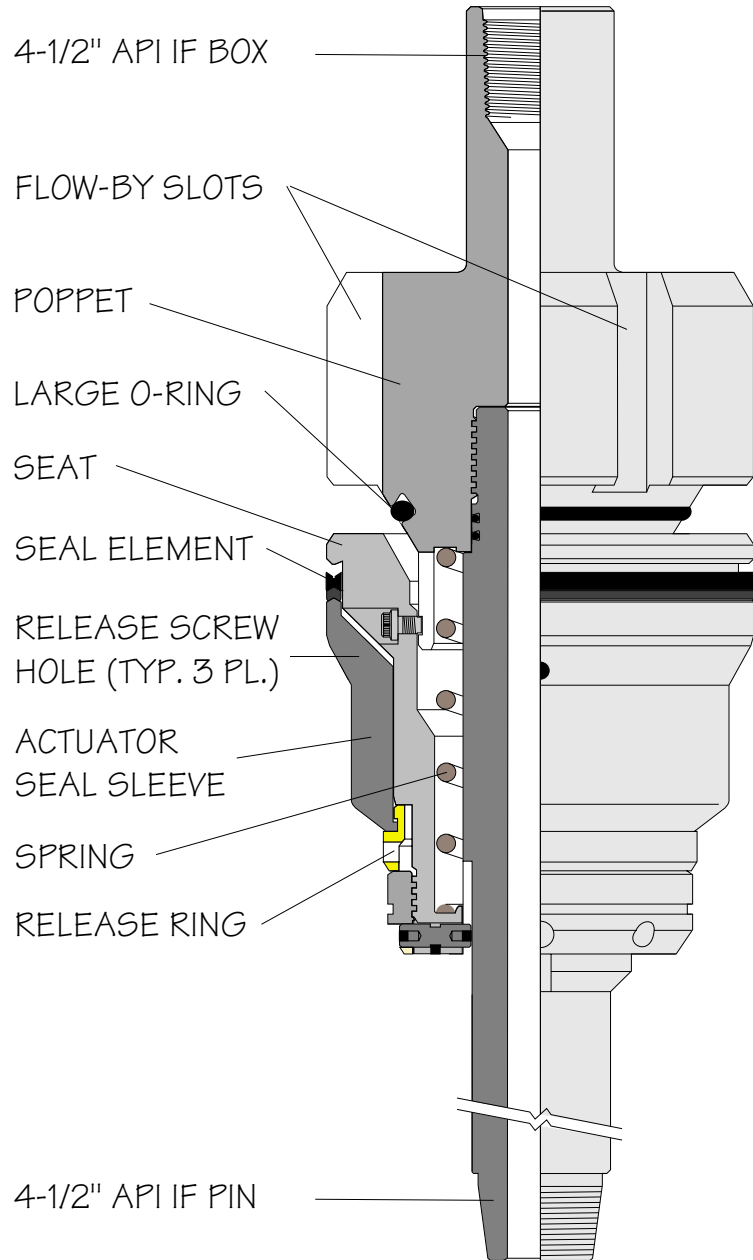

GO BACK

FIGURE 2.

*Wellhead Housing
Adapter*

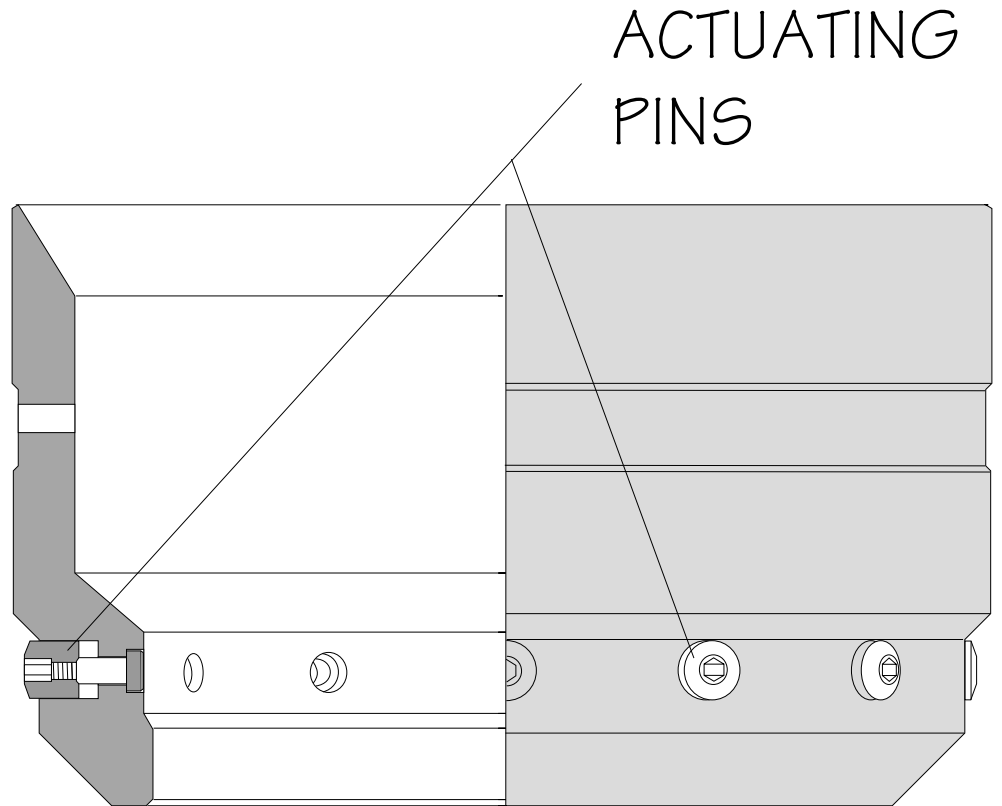

GO BACK

FIGURE 3.

*BOP Test Tool with
Wellhead Adapter
installed*

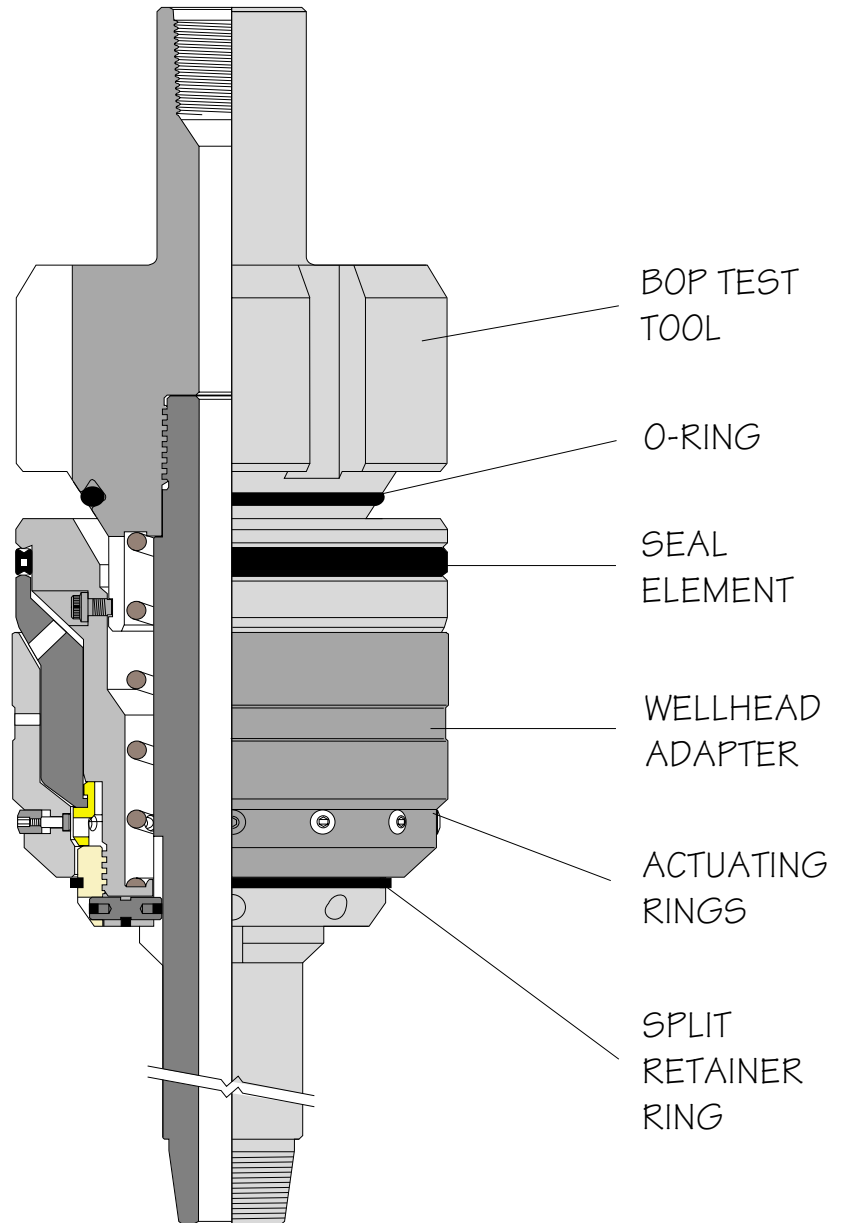

GO BACK

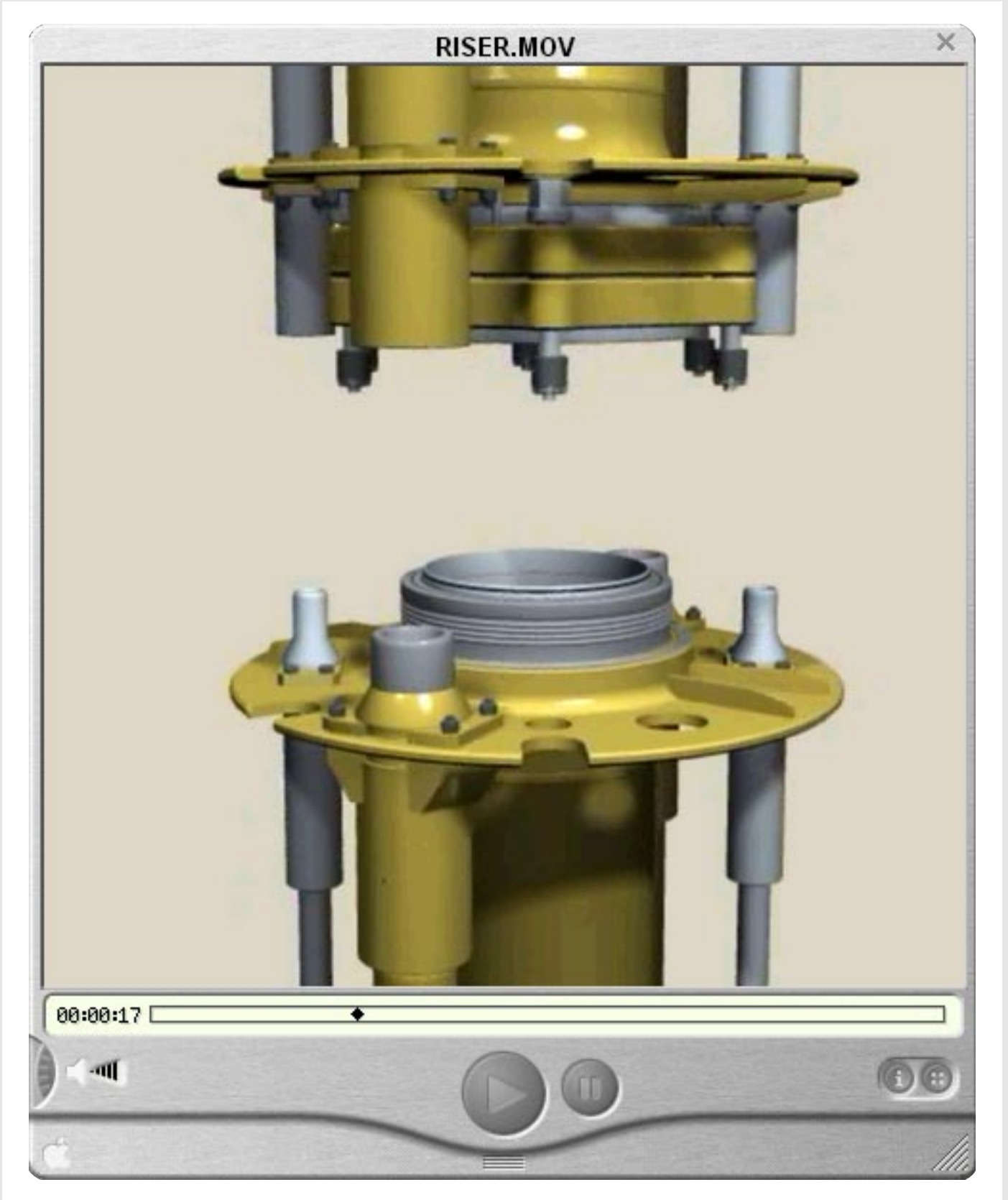

DEMO (movie not playable)

Normally, the Quicktime window would launch and play automatically